

### Features/Benefits

- Includes safety features and emergency override
- Door operates independent of vehicle power to assure emergency egress if necessary
- Smoothly open and close doors up to a 30% slope
- Door can be configured for one-touch auto-open
- Intelligent battery charging from vehicle's power
- Doors can be configured to disable unwanted ingress
- Door perimeter strips prevent pinch accidents
- Multiple choices for door actuation (hydraulic or electromechanical)
- Customizable for your specific application/needs



### Description

The Power Door System (PDS) provides a patented solution for opening/closing the most heavily armored vehicle doors, even when on sloping terrain. The feature-rich powered door system provides the vehicle crew with the ability to operate the doors even when the truck power system is inoperable.

The PDS limits ingress by unwanted personnel, provides emergency egress, and features programmable stop locations, intelligent battery charging, and a host of other provisions that enhance the operation, efficiency, and safety of the occupants.

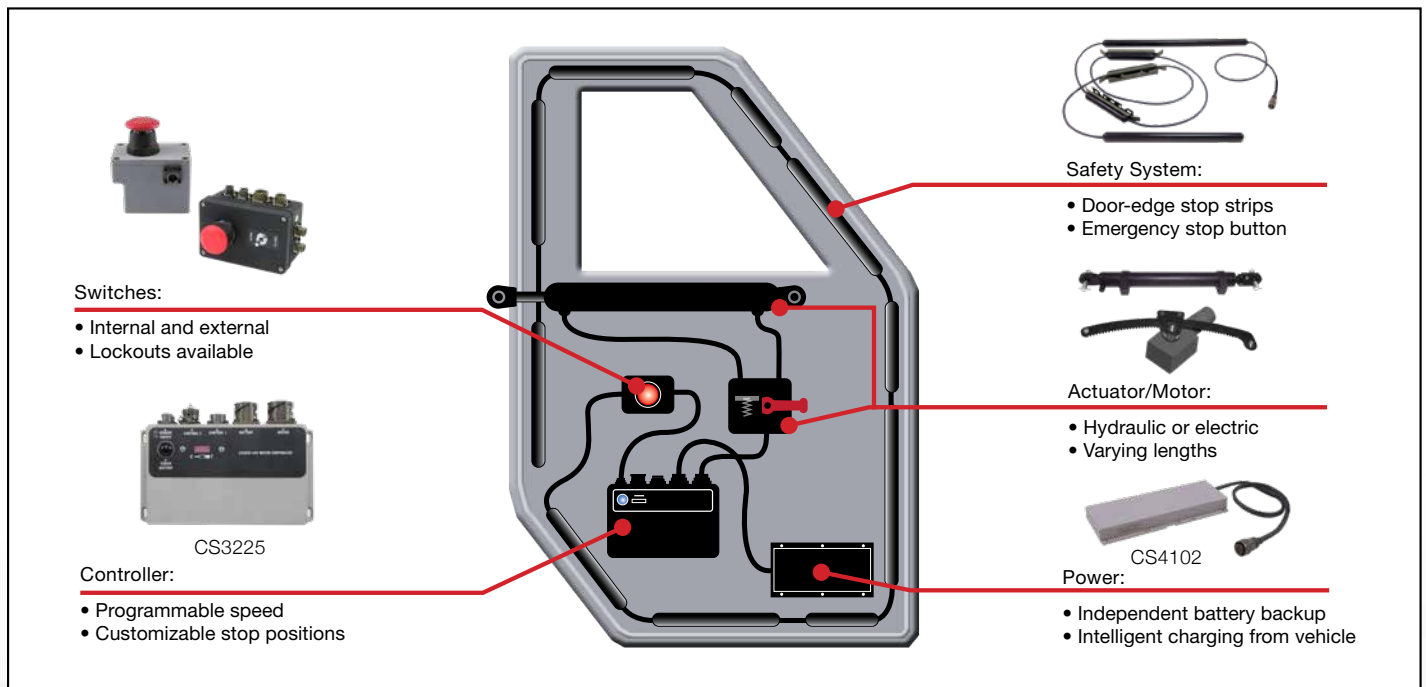

Representative sample configuration (call for vehicle integration).

This product is covered by one or more of the following patents: US 8002328, US 7959211 and US Design D632554.



Visit our website:  
[www.controls.com](http://www.controls.com)



BR0122-00