

CS1202 & CS1202B

24V Lead-Acid Onboard Battery Chargers

Features/Benefits

- Five-stage charging, when used with the CS11XX series motor controllers: cell preparation, charge qualification, bulk charge, cell balancing, and float charge
- Protection against short circuits on the output – Automatic recovery on short removal
- Universal power input 120/220 VAC., Protection against: AC surges on input, battery reverse polarity, protection against over temperature conditions – Automatic recovery
- Charging indication is displayed on the external battery capacity display or LED
- Constant voltage (not pulsed) to reduce battery heating and increase battery life
- Accurate float charge voltage allows charger to be left connected to batteries indefinitely to maintain full charge



- Extruded aluminum enclosure for EMI shielding and water resistance
- Switching power supply provides higher power output with smaller size and weight than traditional liner chargers
- Less than 8 hour recharge for battery capacity under 24 Amp-Hours (ANSI measurement method)

Description

These chargers are designed to be used in conjunction with the CS11XX series motor controllers to charge two 12V, 17 Amp-Hour (or larger) sealed lead acid batteries wired in series.

These chargers are true on-board battery charger, in that they are designed to be mounted permanently on the unit using existing enclosure mounting holes.

When used with a CS11XX series motor controller, the CS11XX controller controls the entire charge cycle and monitors battery conditions to ensure batteries are fully charged without over-charging.

The CS1202B battery charger is UL recognized to the following UL specifications:

CS1202B # UL 60601-1 E319673

About Us

We solve the world's toughest motion control challenges, providing custom solutions focusing on personal mobility and patient transportation products as well as many commercial applications. For over 20 years, Control Solutions LLC has developed a wide array of microprocessor-based control and battery charging solutions designed for flexible integration, feature-rich functionality, and robust performance.



Visit our website:
www.controls.com



Specifications

CS1202/CS1202B* Specifications	Unit of Measure	Minimum	Nominal	Maximum
AC Input	Voltage	90	120	240
AC Input Frequency	Hz	50	60	60
AC Input Current	Amps		0.8	1.2
Peak Charge	Amps			3.7
Output Bulk Charge	Voltage	29.2	29.3	29.4
Output Float Charge	Voltage	27.4	27.6	27.9
Trickle Charge Current	mAmps		50	
Operating Ambient Temperature	°F (°C)	-4 (-20)	77 (25)	113 (45)
Physical Size	Inches (mm)		5.3 x 5.3 x 2.1 (135 x 135 x 53)	
Weight: CS1202/CS1202B	lbs. (Kg)		1.55 (0.70) / 3.02 (1.37)	

The CS1202B battery charger is UL recognized to the following UL specifications:

CS1202B # UL 60601-1 E319673

CS1202 & CS1202B Connectors

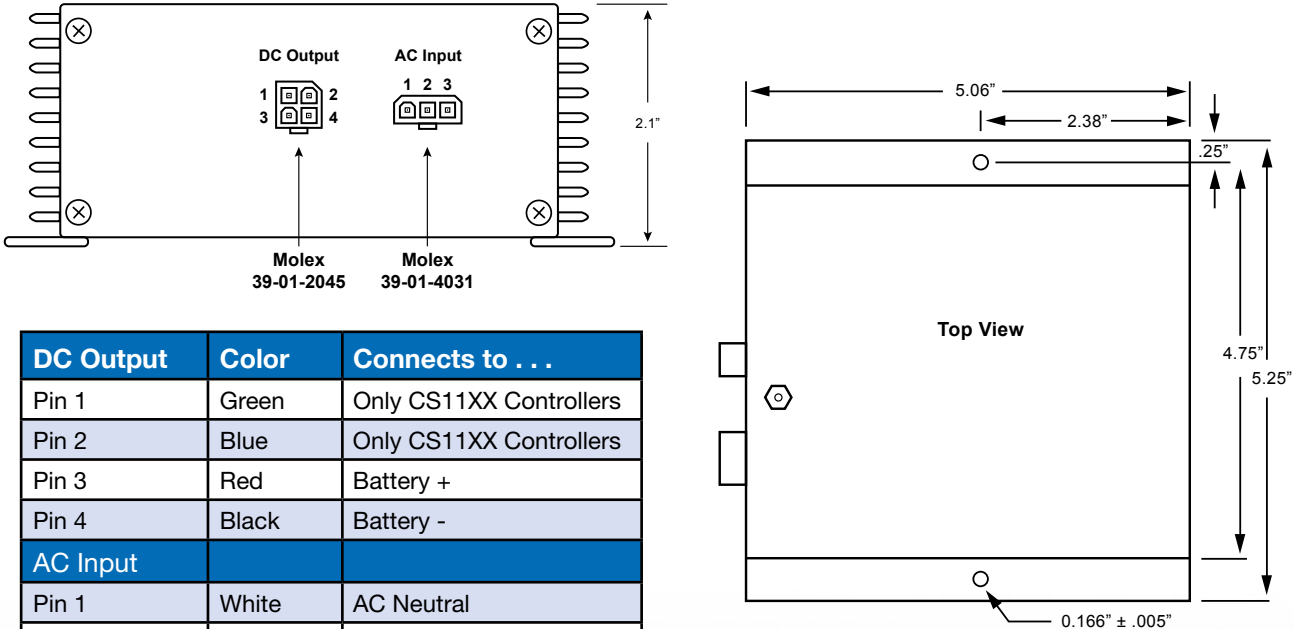

DC Output	Color	Connects to . . .
Pin 1	Green	Only CS11XX Controllers
Pin 2	Blue	Only CS11XX Controllers
Pin 3	Red	Battery +
Pin 4	Black	Battery -
AC Input		
Pin 1	White	AC Neutral
Pin 2	Green	AC Earth Ground
Pin 3	Black	AC Power

Top View

Specifications subject to change without notice.